

Maiwe

Industrial Ethernet Switch

User manual

MIEN2205

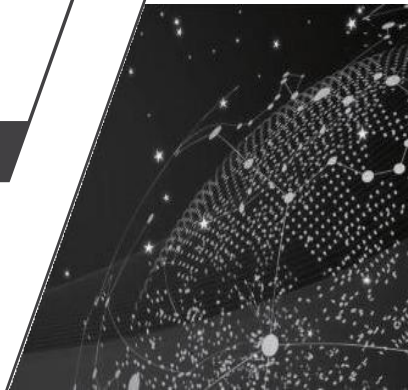

1 Packing list

The package of this switch contains the following items. If any item is found to be missing or damaged, please contact the agent or the customer service center of Maiwe for assistant.

Items	Quantity	Remarks
Industrial Ethernet Switch	1PCS	
User Manual	1PCS	

2 Product description

This series switches are unmanaged din-rail industrial Ethernet switch. MIEN2205 supports 100M Ethernet ports (5*100M copper ports);

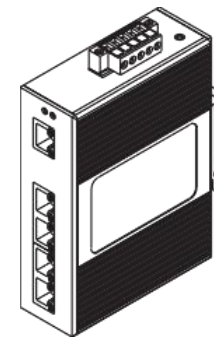

MIEN2205

3 Interface description

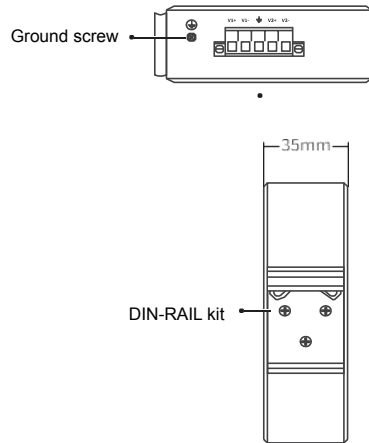

Item	Description
Ground screw	Crimp one end of the grounding screw with the cold-pressed terminal. The other end of the grounding wire is connected to the ground, and the grounding wire is not less than 2.5mm ²
Power interface	Support Dual DC12-48V
Ethernet RJ45 port	Supports automatic MDI/MDI-X connection. You can connect the switch to terminal devices, servers, hubs, or other switches.
Din-rail kit	To fix the switch.

The indicator description of the switch is shown in the following table.

Indicator lights	Status	Definition
System Status LED		
PWR1/PWR2	On	The power is connected and operating normally
	Off	The power is not connected or the system is not operating normally
RUN	Flashing	The system is operating normally (some models are always on to indicate normally)
	Off	The system is not working properly
Fiber Port Status LED		
LINK	On	The port has established a valid network connection
	Flashing	There is network activity on the port
	Off	No valid network connection is established on the port
RJ45 Port Status LED		
Each RJ45 port has two indicator lights, the yellow light is the port plastic rate indicator, the green light is the port connection status indicator.		
10/100M (Yellow)	On	100M working state (namely 100Base-TX)
	Off	10M working status (namely 10Base-T)
Link/Act (Green)	On	The port has established a valid network connection
	Flashing	There is network activity on the port
	Off	No valid network connection is established on the port

4 Hardware installation

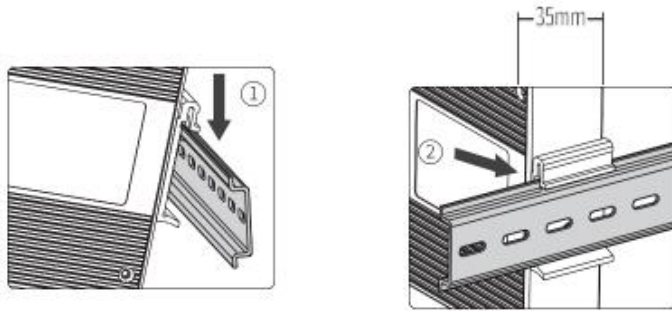

⚠ Installation and safety Precautions

To prevent equipment damage or personal injury caused by improper use, observe the following precautions:

- During the installation process, you need to wear anti-static gloves or anti-static gloves, and power-off the switch.
- Please make sure that the input voltage is within the input voltage range marked on the switch.
- The transmission distance has a certain relationship with the connected wire. It is recommended to use a standard Cat5e/6 network cable.
- The equipment must be grounded for lightning protection, otherwise the protection level of the equipment will be greatly reduced; please use a wire of No. 20 or more to connect the grounding terminal to the ground.
- The power line, ground line and signal line are laid out separately and the distance is not less than 5cm.
- Please pay attention to the symbol below for marking label.

Device installation

- Tilt the switch upwards so that the upper end of the buckle is fastened to the upper end of the DIN rail.

➤ Network cables connection

Connect the optical fiber and network cable to the port in the correct

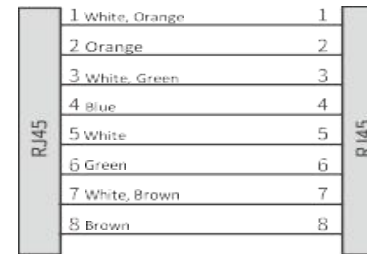
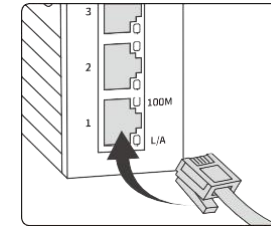

Category 5 direct connection

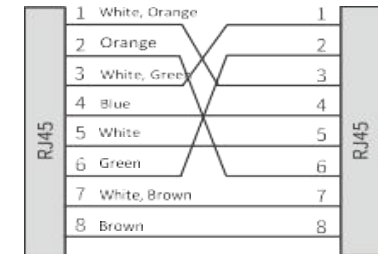

Category 5 crossover connection

➤ Optical fiber connection

Connect the optical fiber to the corresponding optical fiber interface. The optical fiber interface is used in pairs (TX and RX as a pair), TX is optical receiver, RX is optical sender.

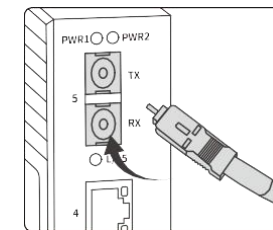

Device connection

 Warning

	Hot Parts
	<ul style="list-style-type: none"> ➤ Burned fingers when handling the parts ➤ Wait one-half hour after switching off before handling the parts

➤ Power input

Before connecting the power cord, make sure that the ground is connected. Do connect the power cord to the power terminal of the device according to the definition.

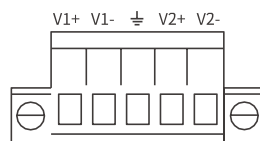
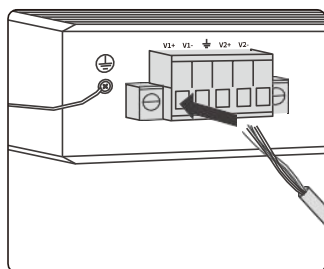

 Notes

1. When using a switch, the voltage can only be input from V1+ and V1-, V1+ connects to live wire L, and V1- to neutral wire N. Do not connect from V2+, V2-; pay attention to safety and prevent electric shock.
2. Power-on operation: First connect the power cord to the power terminal of the device according to the definition shown in the figure above, and then power on.
3. Power-off operation: first unplug the power plug, and then remove the power cord.

	MIEN2205
Switch properties	
Bandwidth	1G
Cache size	748Kbit
MAC table size	2K
Port	
100M Copper port	5*10/100Base-T(X) RJ45 ports Full-duplex/half-duplex adaptive, supports MDI/MDI-X adaptive
Power	
Consumption	1.5W@24V(MAX)
Working current	0.5A
DC power input	DC12-48V d.c.
	Supports dual power supply redundancy and reverse connection protection
Mechanical	
Size	118mm×35mm×86mm (L×W×H) (not include din-rail)
Installation	35mm standard din-rail
Heat	Aluminum alloy single-rib chassis surface scattered
Weight	about 0.64kg
Working Environment	
Working Temp.	-40℃~85℃
Storage Temp.	-40℃~70℃
Humidity	5%~95%(No condensation)
Safety	
Safety	UL/CSA/IEC/EN 62368-1, 2nd
EMC	

5 Specifications

EMC	IEC61000-4-2(ESD),Level 4
	IEC61000-4-5(Surge),Level 4※Ethernet ports support 6KV lightning protection
	IEC61000-4-4(EFT),Level 4
	IEC61000-4-3(RS),Level 4
	IEC61000-4-6(CS),Level 4

6 Order guide

Item	10/100Base-T(X)	100Base-FX	Power
MIEN2205	5	0	DC: DC12-48V d.c

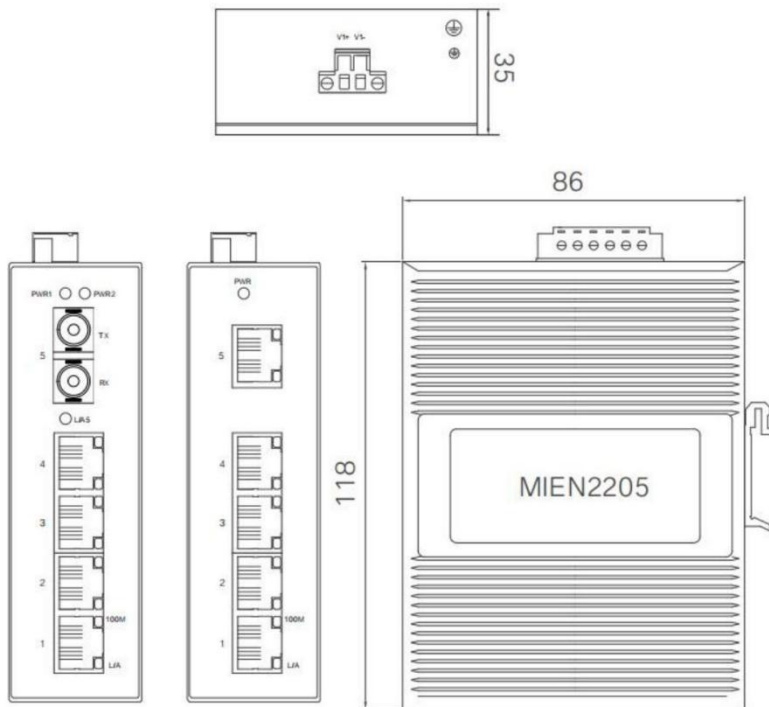

7 Pledge

Thank you for purchasing Maiwe products. You will enjoy the following services when using Maiwe products.

We solemnly promises: under normal use, one month's return, one-year free maintenance, five-year warranty, and lifetime maintenance. The specific details are as follows:

- If Maiwe products have quality problems and cannot work normally, they will be refunded for one month, free maintenance for one year, warranty for five years, and maintenance for life.
- If the number of repaired products is less than 10, the repair service will be completed within 7 days (excluding transportation time), and the repair service will be completed within one month for more than 10 sets.
- Optical passive products such as optical fibers, optical cables, jumpers, flanges, and optical cable terminal boxes are guaranteed within two years, but no return service is provided.
- The accessories and power supply that come with the product are guaranteed for one year.
- When sending the product back to Maiwe for repair, it is recommended that the customer use the original packaging or the packaging with the same protective effect, otherwise the customer shall bear the risks that occur during the transportation.
- The repaired product can enjoy another 6 months warranty service.
- The product after-sales service is detailed in the purchase and sale contract, and Maiwe has the final interpretation right of this description.

Wuhan Maiwe Communication Co., Ltd.

Add: Building E2, No. 2 Building, Area E, No. 52 Liufang Avenue, East lake

High-tech Development Zone, Wuhan, China.

Tel: 027-87170215/16 Fax: 027-87170217

Post Code: 430205

Site: www.maiwe.com



Statement

Due to the continuous updating and improvement of products and technologies, the contents of this manual will be updated from time to time. All the information in the manual is only used for instructions, if the content in the text does not completely match the actual product, please understand and please contact our customer service in time.

Copyright 2021 Maiwe Communication All rights reserved.

The right to interpret the information published in this material belongs to

Wuhan Maiwe Communication Co., Ltd.